

# TOSHIBA

## INSTRUCTION MANUAL

### 3 CCD CAMERA

# IK-TF5

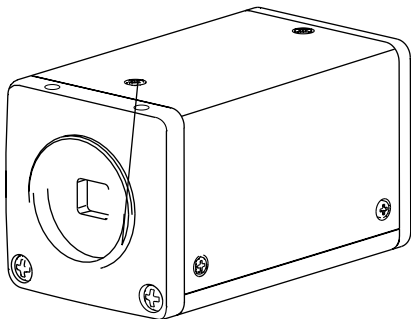

#### For Customer Use

Enter below the Serial No. which is located on the bottom of the cabinet. Retain this information for future reference.

Model No.: IK-TF5 \_\_\_\_\_

Serial No.: \_\_\_\_\_

#### INFORMATION

This equipment has been tested and found to comply with the limits for a Class A digital device, pursuant to Part 15 of the FCC Rules. These limits are designed to provide reasonable protection against harmful interference when the equipment is operated in a commercial environment. This equipment generates, uses, and can radiate radio frequency energy and, if not installed and used in accordance with the instruction manual, may cause harmful interference to radio communications. Operation of this equipment in a residential area is likely to cause harmful interference in which case the user will be required to correct the interference at his own expense.

**USER-INSTALLER CAUTION:** Your authority to operate this FCC verified equipment could be voided if you make changes or modifications not expressly approved by the party responsible for compliance to Part 15 of the FCC Rules.



This Class A digital apparatus complies with Canadian ICES-003.

Cet appareil numérique de la classe A est conforme à la norme NMB-003 du Canada.

# SAFETY PRECAUTIONS

Read the following safety precautions carefully before using this product. These instructions contain valuable information on safe and proper use that will prevent harm and damage to the operator and other persons. Make sure that you fully understand the following details (indications, graphic symbols) before proceeding to the remaining sections in this manual.

## Indication definitions



Indication	Meaning
 <b>Warning</b>	This indicates the existence of a hazard that death or catastrophic bodily injury* <sup>1</sup> may result from improper use.
 <b>Caution</b>	This indicates the existence of a hazard that bodily injury* <sup>2</sup> or property damage* <sup>3</sup> may result from improper use.

\*1: Catastrophic bodily injury means loss of eyesight, burns (high and low temperature), shock, fracture, poisoning, etc. which leaves a sequela and require hospitalization or prolonged treatment.

\*2: Bodily injury means injuries, burns and electric shock which does not require hospitalization or prolonged treatment.

\*3: Property damage means extended harm to home, household effects, domesticated animals, and pets.

## Graphic symbol definitions

Symbol	Meaning
	“⊘” indicates a prohibited action that must not be carried out. The actual prohibited action is indicated in the symbol or nearby graphically or described in text.
	“●” indicates a mandatory action that must be carried out. The actual instruction is indicated in the symbol or nearby graphically or described in text.

## Warning

- **Stop operation immediately when any abnormality or defect occurs.**



Use during an abnormal condition; such as emitting smoke, burning odors, damage from dropping invasion of foreign objects, etc. may cause fire and/or electric shock. Be always sure to disconnect the power plug from the electrical outlet (socket) at once and contact your dealer.



- **Avoid installing in a shower room or a bathroom.**  
This may cause fire and/or electric shock.



- **Do not operate in places with possibility of becoming wet.**  
This may cause fire and/or electric shock.



- **Do not repair, disassemble and/or modify by yourself.**  
This may cause fire and/or electric shock. Be always sure to contact your dealer for internal repair, check and cleaning of the product.



- **Use the specified power supply.**  
Otherwise, a fire or an electric shock may occur.



- **Don't place things or materials on the unit.**  
Ingress of foreign materials such as metallic things and liquid into the unit may cause a fire or an electric shock.



- **Do not put the product in an unstable, slanting and/or vibrated place.**  
Drop and/or fail of the product may cause injury.



- **Do not touch the power cord or other connection cables during a thunderstorm.**  
This might cause electric shock.

## Caution

- **Note the following instructions when installing.**
    - Do not put an inflammable material on the product.
    - Do not put the product on an inflammable material such as carpet or blanket.
    - Do not block a vent hole.
    - Do not put the product in a narrow space, since the heat generated from the product may be difficult to emanate.
- If you do not follow the above, the heat generated by the product may cause fire.



- **Do not put the product in direct sunshine and/or high temperature.**  
The temperature inside the product may cause fire.



- **Avoid setting in humid, smoky, vaporized or dusty places. A fire or an electric shock may occur in such places.**  
This may cause fire and/or electric shock.



- **Do not point the lens directly at the sun and/or intensive light such as direct sunlight, etc.**  
Focusing of the light may cause injury of eye and/or fire.



- **Do not put the product in your mouth or swallow any parts.**  
This may cause suffocation and/or injury.



- **Ask your dealer to perform a periodical check and internal cleaning (approx. once every five years).**  
Dust inside the product may cause fire and/or trouble. For check and cleaning cost, please consult your dealer.

## Disclaimer

We disclaim any responsibility and shall be held harmless for any damages or losses incurred by the user in any of the following cases:

1. Fire, earthquake or any other act of God; acts by third parties; misuse by the user, whether intentional or accidental; use under extreme operating conditions.
2. Malfunction or non-function resulting in indirect, additional or consequential damages, including but not limited to loss of expected income and suspension of business activities.
3. Incorrect use not in compliance with instructions in this instruction manual.
4. Malfunctions resulting from misconnection to other equipment.
5. Repairs or modifications made by the user or caused to be made by the user and carried out by an unauthorized third party.
6. Notwithstanding the foregoing, Toshiba's liabilities shall not, in any circumstances, exceed the purchase price of the product.

## Copyright and Right of Portrait

There may be a conflict with the Copyright Law and other laws when a customer uses, displays, distributes, or exhibits an image picked up by a television camera without permission from the copyright holder. Please also note that transfer of an image or file covered by copyright is restricted to use within the scope permitted by the Copyright Law.

# TABLE OF CONTENTS

<b>1. CAUTIONS ON USE AND INSTALLATION</b> .....	<b>5</b>	<b>7. 3 External Sync</b> .....	<b>22</b>
<b>2. COMPONENTS</b> .....	<b>5</b>	( 1 ) External sync signal input conditions .....	22
<b>3. ITEMS CONTROLLED BY USING ON SCREEN DISPLAY</b> .....	<b>6</b>	( 2 ) External sync frequency range .....	22
<b>4. NAMES AND FUNCTIONS</b> .....	<b>7</b>	( 3 ) Using the unit with external sync signal ..	23
<b>5. CONNECTION</b> .....	<b>8</b>	( 3. 1 ) H (horizontal) phase adjustment.....	23
5. 1 Standard Connection .....	8	( 4 ) Changing HD/VD input/output .....	23
5. 2 Cautions on Connection .....	8	<b>7. 4 Synchro. Scan Operatin</b> .....	<b>23</b>
5. 3 Connector Pin Assignments .....	8	( 1 ) Setting by 1H .....	23
<b>6. OPERATION</b> .....	<b>9</b>	( 2 ) Setting by the frame .....	23
6. 1 White Balance .....	9	<b>7. 5 EXT TRIG (External trigger)</b> .....	<b>24</b>
6. 2 Gain .....	10	( 1 ) 1P SNR (1 Pulse Sync Non Reset) .....	24
6. 3 Shading Correction .....	10	( 1. 1 ) 1 Pulse Trigger SYNC-NON RESET	24
<b>7. MODE SETTING BY ON SCREEN DISPLAY</b> .....	<b>11</b>	Picture Output Timing .....	24
7. 1 Using the Menues .....	11	( 1. 2 ) 1 Pulse Trigger SYNC-NON RESET	24
7. 2 Menus .....	12	Picture Output Timing (at Time of	25
( 1 ) SHUTTER (Electronic shutter) .....	12	Internal Sync) .....	25
( 1. 1 ) Changing each setting in	12	( 2 ) 1P SR (1 Pulse Sync Reset).....	26
MANU mode .....	12	( 2. 1 ) 1 Pulse Trigger SYNC-RESET Picture	26
( 1. 2 ) Changing each setting in	13	Output Timing .....	26
SS (synchro. scan) mode .....	13	( 3 ) PW SNR (Pulse width trigger	27
( 1. 3 ) Changing each setting in	14	SYNC-NON RESET) .....	27
E.TRG mode .....	14	( 3. 1 ) Pulse Width Trigger SYNC-NON RESET	27
( 1. 3. 1 ) Changing each setting in	14	Picture Output Timing .....	27
1P SNR mode .....	14	( 3. 2 ) Pulse Width Trigger SYNC-NON RESET	28
( 1. 3. 2 ) Changing each setting in	15	Picture Output Timing (at Time of	28
1P SR mode .....	15	Internal Sync) .....	28
( 1. 3. 3 ) Changing each setting in	16	( 4 ) PW SR (Pulse width trigger	29
PW SNR mode .....	16	SYNC-RESET) .....	29
( 1. 3. 4 ) Changing each setting in	17	( 4. 1 ) 1 Pulse Width Trigger SYNC-RESET	29
PW SR mode .....	17	Picture Output Timing .....	29
( 1. 3. 5 ) Changing each setting in	18	( 5 ) RR (Reset restart) .....	30
RR mode .....	18	( 5. 1 ) Long Term Exposure .....	30
( 2 ) GAIN (Video gain) .....	18	( 5. 2 ) Input Timing Chart Example .....	30
( 2. 1 ) Changing each setting in GAIN .....	18	<b>7. 6 Partial Read</b> .....	<b>31</b>
( 3 ) WHT BAL (White balance).....	19	( 1 ) Partial Scanning OFF	31
( 3. 1 ) Changing each setting in AWB	19	( All pixels scanning) .....	31
( Automatic White Balance) mode ....	19	( 2 ) Partial Scanning ON .....	31
( 3. 2 ) Changing each setting in MANU	19	( 3 ) When Partial Scanning Mode is ON .....	31
( Manual) mode .....	19	<b>8. INPUT OUTPUT SIGNAL SPECIFICATOINS</b> .....	<b>32</b>
( 4 ) PROCESS .....	20	( 1 ) HD/VD Output Amplitude Specifications ...	32
( 4. 1 ) Changing master pedestal .....	20	( 2 ) VIDEO INDEX Output Specifications ....	32
( 4. 2 ) Changing R pedestal .....	20	( 3 ) VD Input Specifications .....	32
( 4. 3 ) Changing B pedestal .....	20	( 4 ) HD Input Specifications .....	32
( 4. 4 ) Changing White clip .....	20	( 5 ) Trigger Pulse Specifications .....	32
( 4. 5 ) Changing shading correction mode ...	20	( 6 ) External HD/VD Input Phase	32
( 4. 6 ) Changing manual shading correction ..	20	Specifications .....	32
( 5 ) SYNC .....	21	<b>9. CCD OUTPUT WAVEFORM TIMING CHART</b> ...	<b>33</b>
( 5. 1 ) Adjusting horizontal phase .....	21	( 1 ) Horizontal Output Waveform Timing Chart ...	33
( 5. 2 ) Changing RGB SYNC .....	21	( 2 ) Vertical Output Waveform Timing Chart ...	33
( 6 ) OPTION .....	21	<b>10. SPECIFICATIONS</b> .....	<b>34</b>
( 6. 1 ) Changing RS232C communication	21	<b>11. EXTERNAL APPEARANCE DIAGRAM</b> .....	<b>35</b>
baud rate .....	21	<b>12. BEFORE MAKING A SERVICE CALL</b> .....	<b>35</b>
( 7 ) Setting to factory setting status .....	22		

# 1. CAUTIONS ON USE AND INSTALLATION

- **Carefully handle the units.**

Do not drop, or give a strong shock or vibration to the camera. This may cause problems. Treat the camera cables carefully to prevent cable problems, such as cable breakdown and loosened connections.

- **Do not shoot intense light.**

If there is an intense light at a location on the screen such as a spot light, a blooming and smearing may occur. When intense light enters, vertical stripes may appear on the screen. This is not a malfunction. Ghosts may occur when there is an intense light near the object. In this case, change the shooting angle.

- **Install the camera in a location free from noise.**

If the camera or the cables are located near power utility lines or a TV, etc. undesirable noise may appear on the screen. In such a case, try to change the location of the camera or the cable wiring.

- **Moire**

When thin stripe patterns are shot, stripe patterns that are not actually there (moire) may appear as interference stripes. This is not a malfunction.

- **Operating ambient temperature and humidity.**

Do not use the camera in places where temperature and humidity exceed the specifications. Picture quality will lower and internal parts may be damaged.

Be particularly careful when using in places exposed to direct sunlight. When shooting in hot places, depending on the conditions of the object and the camera (for example when the gain is increased), noise in the form of vertical strips or white dots may occur. This is not a malfunction.

- **Handling of the protection cap.**

Keep the protection cap away from children. Children may put them into mouth or swallow them accidentally. The protection cap protects the image sensing plane when the lens is removed from the camera, do not throw away.

- **When not using the camera for a longtime.**

Stop supplying power.

- **When cleaning the camera.**

Always turn off the power and clean with a piece of soft dry cloth. Do not use benzine, alcohol, thinner, household detergents, chemically treated cloths, etc. If used, coating and printed letters may be discolored. When cleaning the lens, use a lens cleaning paper, etc.

- **Avoid using or storing the camera in the following places:**

Places filled with highly flammable gas.

Places near gasoline, benzene, or paint thinner.

Places subject to strong vibration.

Places contacting chemicals (such as pesticides), rubber or vinyl products for a long period of time.

- **For the customers in Europe.**

**WARNING**

This is a Class A product. In a domestic environment this product may cause radio interference in which case the user may be required to take adequate measures. The cable used to connect to the VIDEO OUT DC IN/SYNC plug should be less than 30m in length.

# 2. COMPONENTS

(1) Camera Control Unit .....	1
(2) Accessories	
(a) Instruction manual .....	1

### 3. ITEMS CONTROLLED BY USING ON SCREEN DISPLAY

Item		Available selectins	Preset value (Factory setting)	
Electronic shutter	MODE	MANU, SS, E. TRG	MANU	
	E. TRG	1P SNR, 1P SR, PW SNR, PW SR, RR	1P SNR	
	MANU speed	OFF, 1/100s, 1/250s, 1/500s, 1/1000s, 1/2000s, 1/4000s, 1/10000s, 1/25000s, 1/50000s, 1/1000000s	OFF	
	Syncro. scan.	Partial read OFF	1/525H~524/525H, OFF, 1FRM~512FRM	OFF
		Partial read ON	1/175H~174/175H, OFF, 2FRM~512FRM	
	Partial read	OFF, ON (180 fps)	OFF	
	Trigger (1P SNR/SR)	⌂, ⌄	⌂	
	Trigger (PW SNR/SR)	⌋, ⌌	⌋	
1P exposure time	0.01ms~16ms	16 ms		
Gain	MODE	MANU, OFF	OFF	
	MANU	-3dB~18dB	0dB	
White balance	MODE	AWB, MANU	AWB	
	Color temperature	3200K, 5600K	3200K	
	MANUAL R GAIN	-100~0~100	0	
	MANUAL B GAIN	-100~0~100	0	
Process	Master pedestal	-64~0~64	0	
	R pedestal	-64~0~64	0	
	B pedestal	-64~0~64	0	
	White clip	-50~0~50	0	
	Shading correction mode	MANU, OFF	MANU	
	Manual shading correction	-128~0~127	0	
Sync	H phase adjustment	-100~0~100	0	
	RGB SYNC	G, ALL ON, ALL OFF	G	
Option	Baud rate	9600 bps, 19200 bps	9600 bps	

## 4. NAMES AND FUNCTIONS

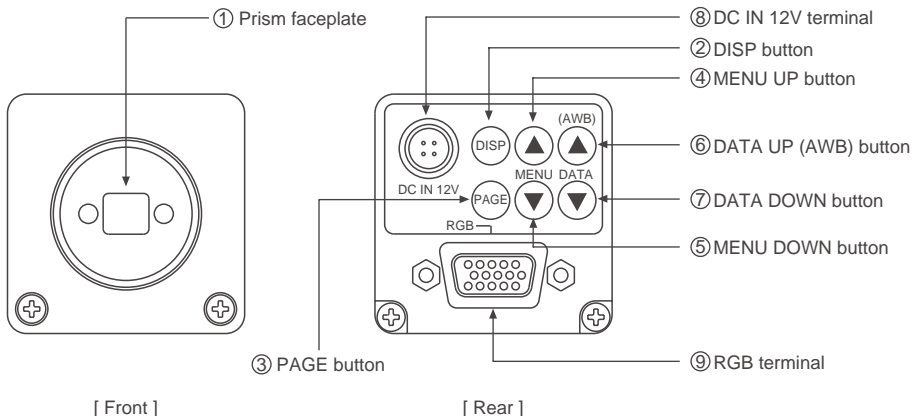

① Prism faceplate

The protection cap is attached on the lens mount portion. After removing the cap, mount the lens. Be careful not to scratch or touch the optical area.

② DISP button

Used when switching the display.

③ PAGE button

Used when switching to the menu and when selecting the menus.

④ MENU UP button

Select the function to be confirmed or changed on the menu.

⑤ MENU DOWN button

Select the function to be confirmed or changed on the menu.

⑥ DATA UP (AWB) button

Changes the value of the function selected by the MENU (UP/DOWN) button. (Also used when using AWB.)

⑦ DATA DOWN button

Changes the value of the function selected by the MENU (UP/DOWN) button.

⑧ DC IN 12V terminal

Accept a DC power input (12V).

⑨ RGB terminal

Used as the connector terminal for RGB output, and SYNC output.

HD and VD signals are input/output. When the random trigger operation is used, the trigger signal is input and the index signal is output. This terminal also includes an RS232C format control.

# 5. CONNECTION

## 5.1 Standard Connection

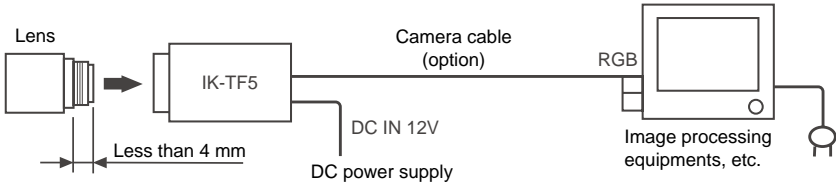

## 5.2 Cautions on Connection

- When connecting the camera cables, be sure to turn off the camera and the other equipment connected.
- We suggest using a C mount lens made for a 3CCD camera.

When using another lens, the best camera performance of this camera may not be obtained.

(For example, low resolution may occur, focus may be lost through the range of a zoom lens, and flare, ghost or shading may occur)

Furthermore, in order to avoid damaging the mounting portion of the camera head, use a lens which has projection dimension from the mounting base of less than 0.157"(4mm).

- For DC power supply connecting to DC IN 12V terminal, use UL listed and/or CSA approved ungrounding type AC adaptor with the specifications described below.

Power supply voltage	: DC12V±10%
Current rating	: More than 830 mA, Less than 2.5A
Ripple voltage	: Less than 50 mV(p-p)
Connector	: HR10A-7P-4S by HIROSE electronics Co. Ltd
	Pins 1, 2 : 12V
	Pins 3, 4 : GND

## 5.3 Connector Pin Assignments

DC IN 12V

1	+12V
2	+12V
3	GND
4	GND

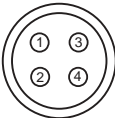

RGB

1	R
2	G
3	B
4	TXD
5	GND
6	GND
7	GND
8	SYNC
9	12V
10	GND
11	RXD
12	TRIG
13	HD IN/OUT
14	VD IN/OUT
15	INDEX

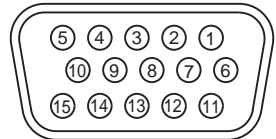

## 6. OPERATION

- ① Referring to the item "5. CONNECTION", connect each equipment correctly.
- ② Turn on the connected equipment and the camera.
- ③ Pointing the lens at the object, operate the lens iris adjustment, focus adjustment, etc..
- ④ Referring to the item "6.1 White Balance", operate the adjustment.
- ⑤ Referring to the items "6.2 Gain, 7. MODE SETTING BY ON SCREEN DISPLAY", select the necessary items.

### 6.1 White Balance

For the white balance adjustment for this unit, AWB (Automatic White Balance) and MANU (Manual white balance) adjustments are provided. Referring to the items "7.2 (3) WHT BAL (White balance), 7. MODE SETTING BY ON SCREEN DISPLAY", select the desired mode.

	<b>AWB (Automatic White Balance)</b>	<b>MANU (Manual White Balance)</b>
<b>Outline</b>	Adjust white balance by displaying the white object inside the area set by AWB menu and pressing the [DATA UP] button.	Adjust the white balance manually using the WHT BAL menu while shooting the white object.
<b>Notes</b>	When the shutter mode is EXT TRIG, AWB is not available.	Adjustment is performed by confirming with a waveform monitor.

- ① AWB (Automatic white balance)
  - Set the MODE to AWB on the WHT BAL menu.  
Perform the C.TEMP (color temperature conversion) setting, if necessary.  
(Refer to the item "7.2 (3) WHT BAL (White balance)".)
  - 3200K : Appropriate for indoor shooting.
  - 5600K : Appropriate for outdoor shooting.
  - If the index menu/menu is displayed, press the [DISP] button to disable the color bar pattern or the character display on the menu.
  - Shoot a known white object that fills the screen and push [DATA UP] button for approx. 1 second.
  - The character AWB blinks on the screen when the AWB starts.
  - The character AWB stops blinking when the AWB finishes, and the result is displayed for approx. 1 second.

<b>Result displayed</b>	<b>Meaning</b>
<b>AWB OK</b>	Automatic white balance adjustment finished correctly.
<b>AWB NG LEVEL LOW</b>	Automatic white balance adjustment cannot be performed because the video level is too low. Set the video level properly.
<b>AWB NG LEVEL HIGH</b>	Automatic white balance adjustment cannot be performed because the video level is too high. Set the video level properly.
<b>AWB NG C. TEMP HIGH</b>	Automatic white balance adjustment cannot be performed because the color temperature is too low. If the C.TEMP is set to 5600K, set to 3200K. If the message appears with the C.TEMP set to 3200K, change the illumination or use a color temperature conversion filter.
<b>AWB NG C. TEMP HIGH</b>	Automatic white balance adjustment cannot be performed because the color temperature is too high. If the C.TEMP is set to 3200K, set to 5600K. If the message appears with the C.TEMP set to 5600K, change the illumination or use the color temperature conversion filter.

Result displayed	Meaning
<b>AWB NG NOT AVAILABLE</b>	Automatic white balance adjustment cannot be performed because the shutter speed mode is EXT TRIG mode.
<b>AWB NG</b>	Automatic white balance adjustment cannot be performed for other reasons. Such as no white area is included in an object, etc.

- ② MANU (Manual white balance)
- Set the MODE to MANUAL on the WHT BAL menu.  
(Refer to the item "7.2 (3) WHT BAL (white balance)".)
  - Shoot a known white object, adjust the white balance adjusting the levels of R GAIN and B GAIN on the menu, confirming with a monitor or a waveform monitor.  
(Refer to the item "7.2 (3) (3.2) Changing each setting in MANU mode".)

## 6.2 Gain

When the image is dark even if the lens iris is open, change the gain (video gain) to get the proper video level. For the gain adjustment of the unit, MANUAL (Manual) and OFF (0 dB) modes are provided. Select the mode on the GAIN menu. (Refer to the item "7.2 (2) GAIN (Video gain)".)

- ① MANU (Manual gain)
- Gain adjustment is performed on the GAIN menu. The adjustment range is from -3dB to 18dB in 1dB steps. (Refer to the item "7.2 (2) (2.1) (a) Changing the gain in MANUAL mode".)
- ② OFF
- Gain is fixed at 0 dB.

## 6.3 Shading Correction

Due to the lens used or the environmental condition, vertical color shading may occur at the top and bottom of the screen. In this case, the shading correction can decrease the color shading. For the shading correction of the unit, MANU (Manual shading correction) and OFF (no shading correction) modes are provided. Select the mode on the PROCESS menu. (Refer to the item "7.2 (4) (4.5) Changing shading correction mode".)

- ① MANU (Manual Shading)
- Perform the correction amount setting on the PROCESS menu, confirming with a monitor or a waveform monitor. (Refer to the "7.2 (4) (4.6) Changing the manual shading correction setting".)
- ② OFF
- The status is no shading correction.

**\* The shading correction is effective when the lens iris or zoom ratio is fixed. Use the unit with SHADING OFF for variable lens conditions.**

# 7. MODE SETTING BY ON SCREEN DISPLAY

Various settings can be controlled on the unit by using the on screen menu displayed on the monitor. The contents once set are memorized when the power is turned off, so it is unnecessary to set again when using the unit next time. When the setting is performed, select the menu of the item to be set.

## 7.1 Using the Menus

When the power turns on, the normal screen showing only the video signal appears. Change the output to each screen (video signal output, Index menu, and menus) by using the [DISP], [PAGE], [MENU UP], and [MENU DOWN] buttons.

\* A menu is selected when pushing the [PAGE] button after moving the "→" on the screen by the [MENU UP], [MENU DOWN] button while the Index menu is displayed.

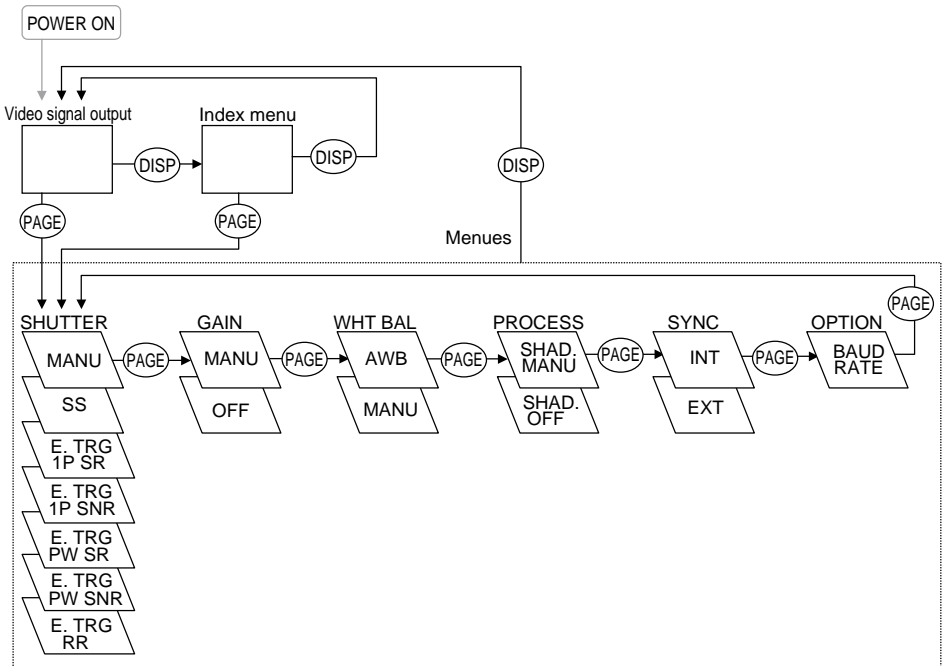

## 7.2 Menus

- Select the menu to change the setting by referring the item "7.1 Using the Menues".)
- When the [MENU UP], [MENU DOWN] buttons are pushed, the "→" on the screen moves up and down. Move the "→" to the item to change.

### (1) SHUTTER (Electronic shutter)

The electronic shutter has three modes; MANU (Manual), SS (Synchro. Scan), EXT TRIG (External trigger).

Set the "→" to "MODE" and push [DATA UP], [DATA DOWN] button to select the desired mode among "MANU", "SS", "EXT TRIG".

#### (1.1) Changing each setting in MANU mode

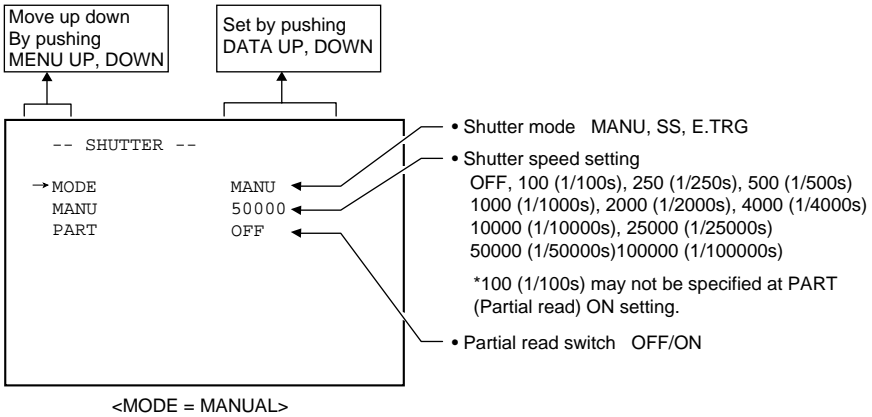

#### (a) Changing the shutter speed

- ① Set the "→" to MANU by pushing [MENU UP], [MENU DOWN] buttons.
- ② Set the shutter speed by pushing [DATA UP], [DATA DOWN] buttons.

#### (b) Partial read setting

- ① Set the "→" to PART by pushing [MENU UP], [MENU DOWN] buttons.
- ② Select either OFF or ON by pushing [DATA UP], [DATA DOWN] buttons.

**(1. 2) Changing each setting in SS (synchro. scan) mode**

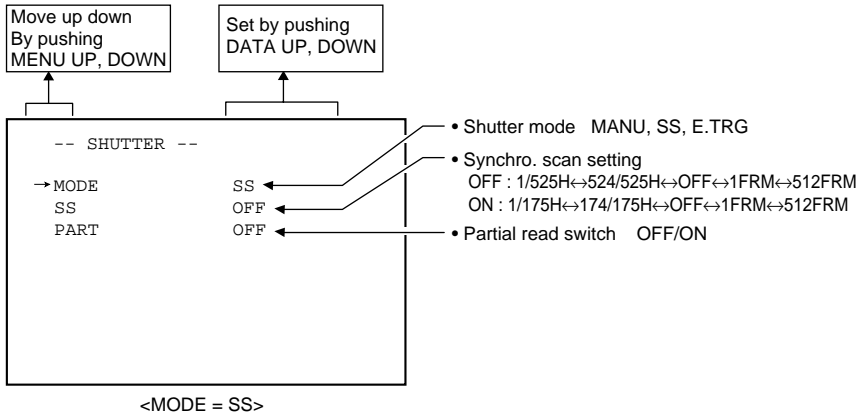

**(a) Changing the shutter speed setting**

- ① Set the "→" to SS by pushing [MENU UP], [MENU DOWN] buttons.
- ② Select the shutter speed by pushing [DATA UP], [DATA DOWN] buttons.

**(b) Partial read setting**

- ① Set the "→" to PART by pushing [MENU UP], [MENU DOWN] buttons.
- ② Select either OFF or ON by pushing [DATA UP], [DATA DOWN] buttons.

**Note:**

**The longer the storage time with extended exposures, the more visible certain characteristics of CCD cameras become: fixed pattern noise, white pixels, etc.**

### (1. 3) Changing each setting in E.TRG mode

The E.TRG has five modes; 1P SNR, 1P SR, PW SNR, PW SR, RR.

First set the "→" to MODE and select E. TRG, then set the "→" to E.TRG and select the desired E.TRG mode.

#### (1. 3. 1) Changing each setting in 1P SNR mode

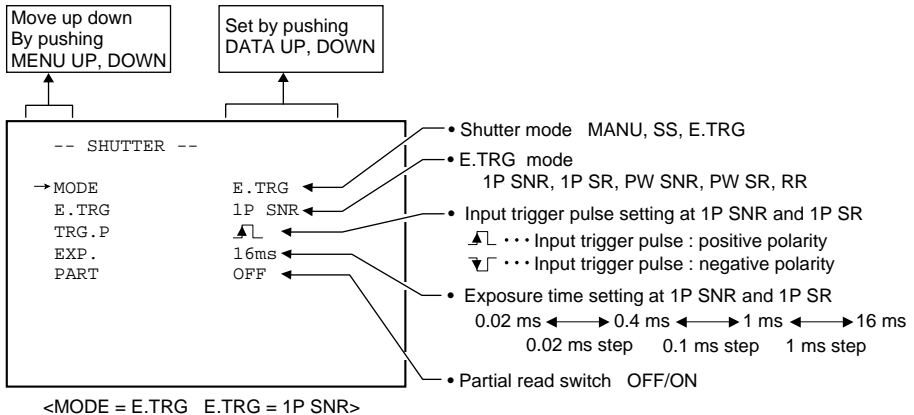

#### (a) Changing the polarity of inputting trigger pulse setting

- ① Set the "→" to TRG.P by pushing [MENU UP], [MENU DOWN] buttons.
- ② Select either ▲ ▭, ▼ ▭ by pushing [DATA UP], [DATA DOWN] buttons.

#### (b) Changing 1P SNR exposure time setting

- ① Set the "→" to EXP. by pushing [MENU UP], [MENU DOWN] buttons.
- ② Set the exposure time by pushing [DATA UP], [DATA DOWN] buttons.

#### Note:

**The longer the storage time with extended exposures, the more visible certain characteristics of CCD cameras become: fixed pattern noise, white pixels, etc.**

#### (c) Changing the partial read setting

- ① Set the "→" to PART by pushing [MENU UP], [MENU DOWN] buttons.
- ② Select either OFF or ON by pushing [DATA UP], [DATA DOWN] buttons.

**(1. 3. 2) Changing each setting in 1P SR mode**

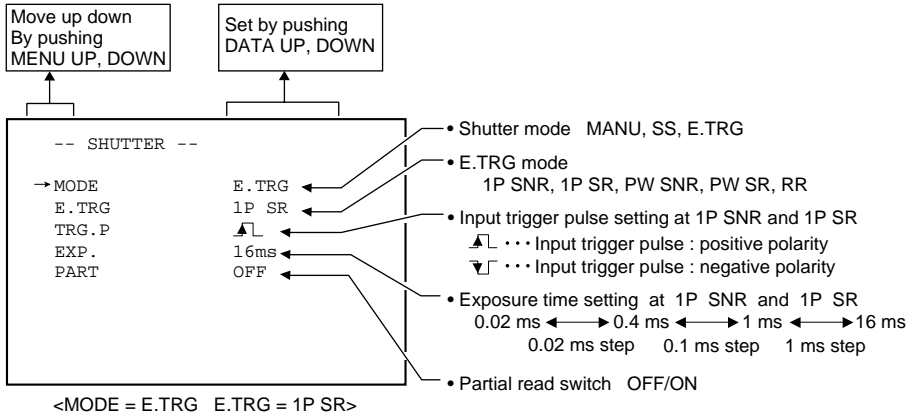

**(a) Changing the polarity of inputting trigger pulse setting**

- ① Set the "→" to TRG.P by pushing [MENU UP], [MENU DOWN] buttons.
- ② Select either ▲ ▭, ▼ ▭ by pushing [DATA UP], [DATA DOWN] buttons.

**(b) Changing 1P SR exposure time setting**

- ① Set the "→" to EXP. by pushing [MENU UP], [MENU DOWN] buttons.
- ② Set the exposure time by pushing [DATA UP], [DATA DOWN] buttons.

**Note:**

**The longer the storage time with extended exposures, the more visible certain characteristics of CCD cameras become: fixed pattern noise, white pixels, etc.**

**(c) Changing the partial read setting**

- ① Set the "→" to PART by pushing [MENU UP], [MENU DOWN] buttons.
- ② Select either OFF or ON by pushing [DATA UP], [DATA DOWN] buttons.

### (1. 3. 3) Changing each setting in PW SNR mode

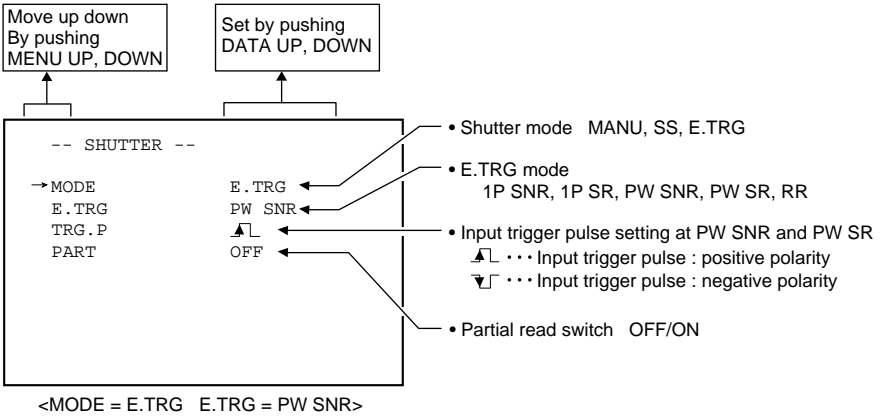

#### (a) Changing the polarity of inputting trigger pulse setting

- ① Set the "→" to TRG.P by pushing [MENU UP], [MENU DOWN] buttons.
- ② Select either ▲, ▼ by pushing [DATA UP], [DATA DOWN] buttons.

#### (b) Changing the partial read setting

- ① Set the "→" to PART by pushing [MENU UP], [MENU DOWN] buttons.
- ② Select either OFF or ON by pushing [DATA UP], [DATA DOWN] buttons.

#### Note:

**The longer the storage time with extended exposures, the more visible certain characteristics of CCD cameras become: fixed pattern noise, white pixels, etc.**

**(1. 3. 4) Changing each setting in PW SR mode**

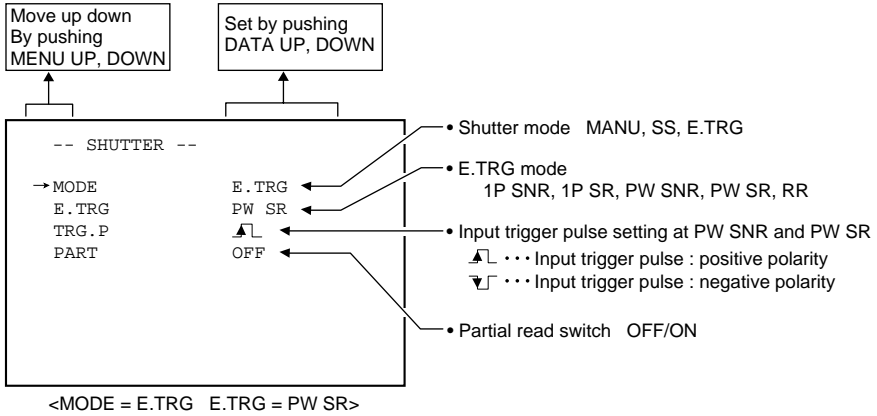

**(a) Changing the polarity of inputting trigger pulse setting**

- ① Set the "→" to TRG.P by pushing [MENU UP], [MENU DOWN] buttons.
- ② Select either ▲ ▭, ▼ ▭ by pushing [DATA UP], [DATA DOWN] buttons.

**Note:**

**The longer the storage time with extended exposures, the more visible certain characteristics of CCD cameras become: fixed pattern noise, white pixels, etc.**

### (1. 3. 5) Changing each setting in RR mode

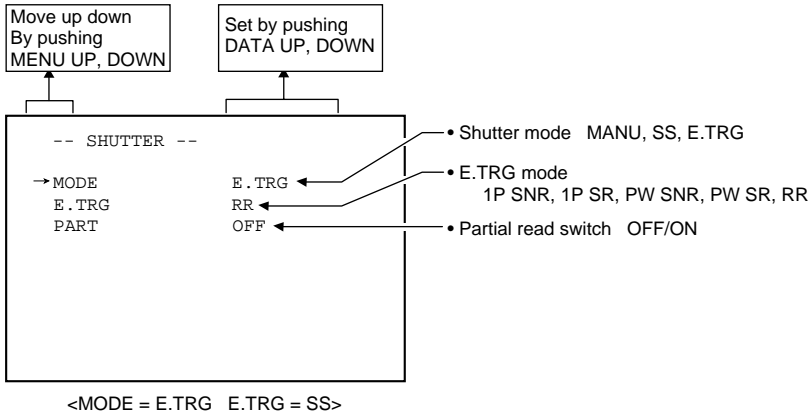

#### (a) Changing the partial read setting

- ① Set the "→" to PART by pushing [MENU UP], [MENU DOWN] buttons.
- ② Select either OFF or ON by pushing [DATA UP], [DATA DOWN] buttons.

#### Note:

The longer the storage time with extended exposures, the more visible certain characteristics of CCD cameras become: fixed pattern noise, white pixels, etc.

## ( 2 ) GAIN (Video gain)

GAIN has two modes; MANU, OFF.

Set the "→" to MODE, push the [DATA UP], [DATA DOWN], and select mode among MANU, OFF. In the OFF mode, gain is fixed to 0dB.

### (2. 1) Changing each setting in GAIN

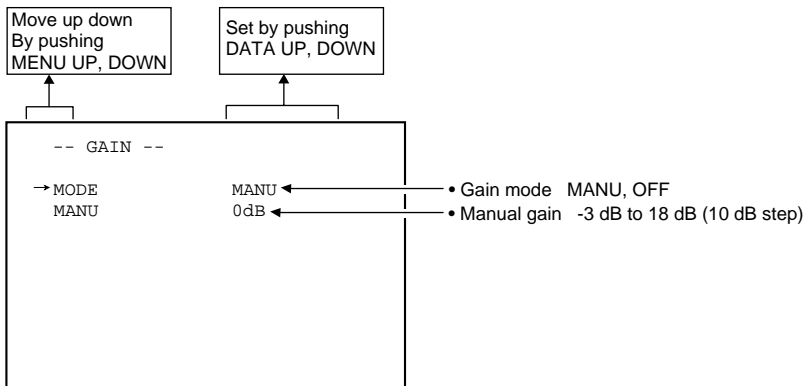

#### (a) Changing the gain in MANU mode

- ① Set the "→" to MANU by pushing [MENU UP], [MENU DOWN] buttons.
- ② Set the manual gain by pushing [DATA UP], [DATA DOWN] buttons.

### ( 3 ) WHT BAL (White balance)

WHT BAL has two modes; AWB, MANU.

Set the "→" to MODE, push the [DATA UP], [DATA DOWN], and select mode among AWB, MANU.

#### (3. 1) Changing each setting in AWB (Automatic White Balance) mode

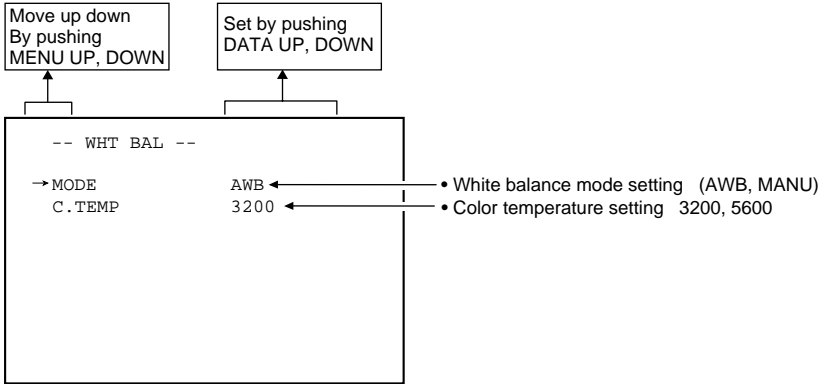

#### (a) Changing color temperature setting

- ① Set the "→" to C. TEMP by pushing [MENU UP], [MENU DOWN] buttons.
- ② Select either 3200 or 5600 by pushing [DATA UP], [DATA DOWN] buttons.

#### (3. 2) Changing each setting in MANU (Manual) mode

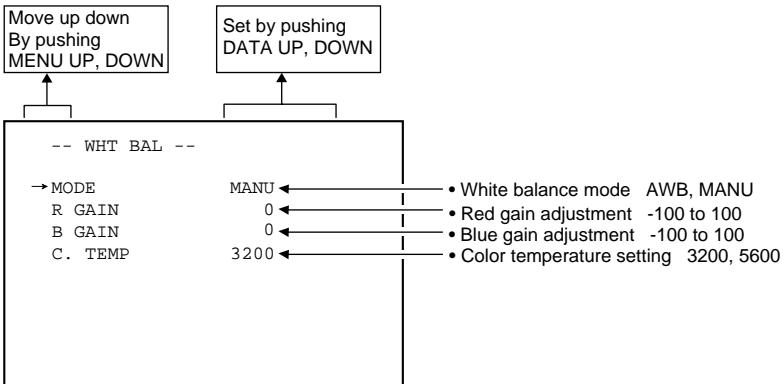

#### (a) Changing the red gain

- ① Set the "→" to R GAIN by pushing [MENU UP], [MENU DOWN] buttons.
- ② Set the red gain by pushing [DATA UP], [DATA DOWN] buttons.

#### (b) Changing the blue gain

- ① Set the "→" to B GAIN by pushing [MENU UP], [MENU DOWN] buttons.
- ② Set the blue gain by pushing [DATA UP], [DATA DOWN] buttons.

## (4) PROCESS

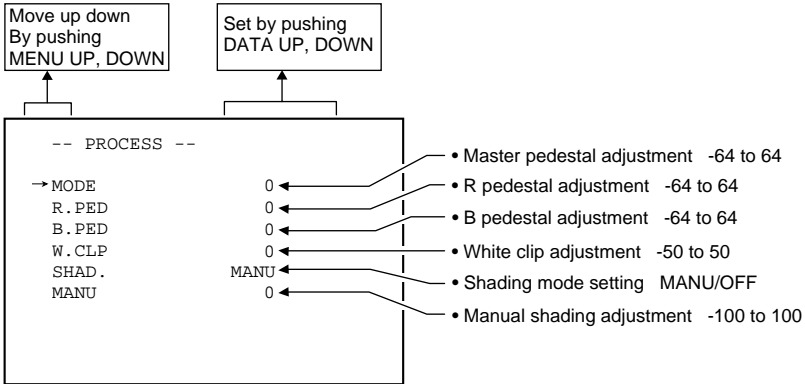

### (4.1) Changing master pedestal

- ① Set the "→" to M. PED by pushing [MENU UP], [MENU DOWN] buttons.
- ② Set the master pedestal by pushing [DATA UP], [DATA DOWN] buttons.

### (4.2) Changing R pedestal

- ① Set the "→" to R. PED by pushing [MENU UP], [MENU DOWN] buttons.
- ② Set the R pedestal by pushing [DATA UP], [DATA DOWN] buttons.

### (4.3) Changing B pedestal

- ① Set the "→" to B. PED by pushing [MENU UP], [MENU DOWN] buttons.
- ② Set the B pedestal by pushing [DATA UP], [DATA DOWN] buttons.

### (4.4) Changing White clip

- ① Set the "→" to W. CLP by pushing [MENU UP], [MENU DOWN] buttons.
- ② Set the W. CLP by pushing [DATA UP], [DATA DOWN] buttons.

**Note:** The alignment value for shading is fixed to "0" when selecting SHAD. OFF. MANU is not displayed in the menu.

### (4.5) Changing shading correction mode

- ① Set the "→" to SHAD. by pushing [MENU UP], [MENU DOWN] buttons.
- ② Set the SHAD. by pushing [DATA UP], [DATA DOWN] buttons.

### (4.6) Changing manual shading correction

- ① Set the "→" to MANU by pushing [MENU UP], [MENU DOWN] buttons.
- ② Set the MANUAL SHADING by pushing [DATA UP], [DATA DOWN] buttons.

## (5) SYNC

When an external sync signal is input, the display changes from INT (internal sync) to EXT (external sync) automatically.

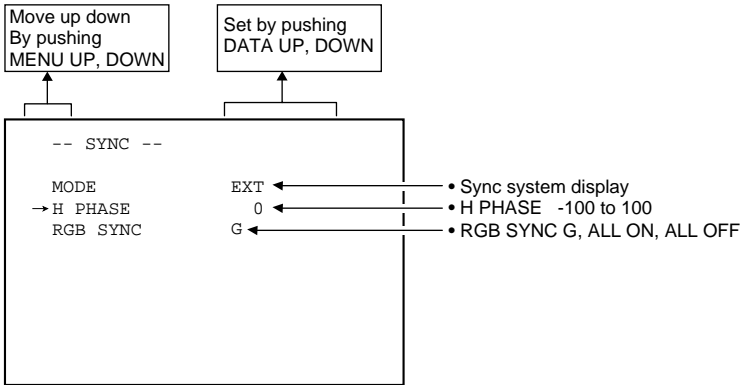

### (5.1) Adjusting horizontal phase

- ① Set the "→" to H PHASE by pushing [MENU UP], [MENU DOWN] buttons.
- ② Adjust the horizontal phase by pushing [DATA UP], [DATA DOWN] buttons.

### (5.2) Changing RGB SYNC

- ① Set the "→" to RGB SYNC by pushing [MENU UP], [MENU DOWN] buttons.
- ② Select G, ALL ON or ALL OFF by pushing [DATA UP], [DATA DOWN] buttons.

## (6) OPTION

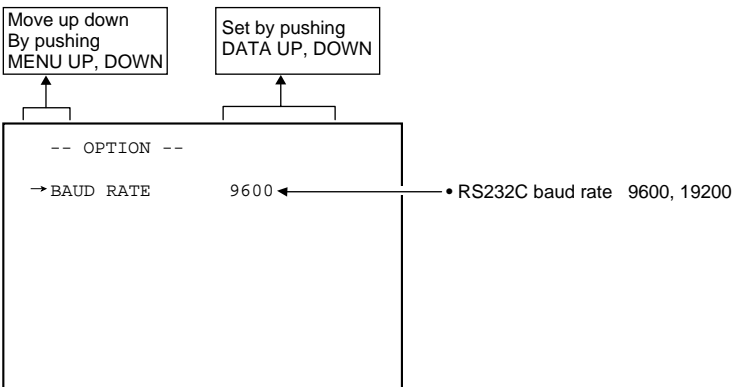

### (6.1) Changing RS232C communication baud rate

- ① Set the "→" to BAUD RATE by pushing [MENU UP], [MENU DOWN] buttons.
- ② Select either 9600 or 19200 by pushing [DATA UP], [DATA DOWN] buttons.

## **( 7 ) Setting to factory setting status**

The contents set of each scene file can be returned to the factory default status (preset status).

- (1) If characters are displayed on the screen, press the [DISP] button to disable the character display.
- (2) Push [MENU DOWN] and [DATA DOWN] buttons simultaneously for approx. 1 second.
- (3) The preset operation starts. When the preset operation finishes, the character PRESET OK is displayed for approx. 1 second.

### **7.3 External Sync**

When using the unit with an external sync signal, input HD and VD to RGB terminal on the rear panel, or input SYNC to RGB terminal. When the external sync signal is input, the camera automatically switches its sync from the internal sync to the external sync.

The operation is as shown below, depending on the unit's status and how external sync signals are input.

<b>Shutter mode</b>	<b>HD input</b>	<b>VD input</b>	<b>Note</b>
At time of SYNC-NON RESET mode	N	N	Internal sync mode
	Y	Y	External sync mode
	N	Y	Only V reset is applied due to VD input. Normally not used.
	Y	N	HD is synchronized to external, but video is not output because there is no VD input. Normally not used.
At time of SYNC-RESET mode	N	*	Internal sync mode. The presence of VD is ignored, and after a specified time after a trigger input, V reset is applied.
	Y	*	HD is synchronized to external. The presence of VD is ignored, and after a specified time after a trigger input, V reset is applied.
At time of reset restart	Y	Y	HD is synchronized to external. Video is output due to VD input.
	N	Y	HD is synchronized to the inside of the camera. Video is output due to VD input.
	*	N	Video is not output because there is no VD input. Normally not used.
At time of manual shutter	N	N	Internal sync mode
	Y	Y	External sync mode
	Y	N	HD is synchronized to external. Normally not used.
	N	Y	Disabled

\* Either Y or N is permitted.

### **( 1 ) External sync signal input conditions**

HD: 2 to 5V(p-p) Negative

VD: 2 to 5V(p-p) Negative

### **( 2 ) External sync frequency range**

(External sync with HD, VD)

For EIA standard frequency : Within  $\pm 1\%$  (at horizontal sync frequency of 31.469 kHz)

**( 3 ) Using the unit with external sync signal**

When adjusting H (horizontal) phase refer to the item "7.2 (5) (5.1) Adjusting horizontal phase".

**(3. 1) H (horizontal) phase adjustment**

Observe the external sync signal and the video signal output waveform of the unit with a dual trace oscilloscope, and adjust H phase so that the H phases match.

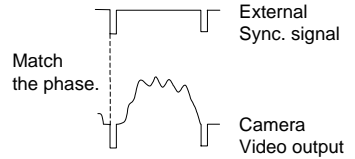

**( 4 ) Changing HD/VD input/output**

- (1) Put off 6 screws both on flank/top of camera chassis.
- (2) Change internal switch SJ01(HD/VD).

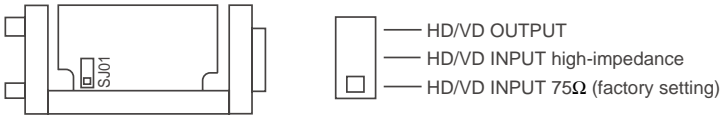

**7. 4 Synchro. Scan Operation**

The shutter speed can be set by the horizontal scanning period (1H) or by the frame.

**( 1 ) Setting by 1H**

1/525H to 524/525H stands for the setting by the 1H and the shutter speed can be set by the 1H (31.8 ms).

**( 2 ) Setting by the frame**

1FRM to 512FRM stand for the setting (long period exposure) by the frame.

The video signal stored during the frame period set is output as 1 frame video image at a frame interval specified.

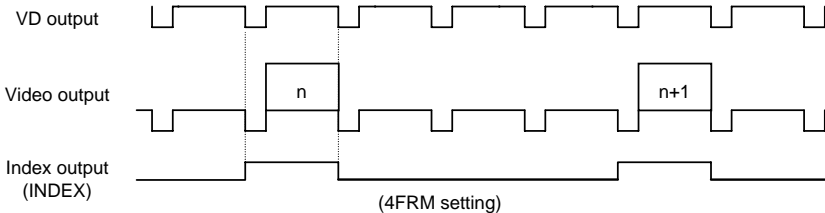

## 7.5 EXT TRIG (External trigger)

Charge begins to accumulate after the trigger input, and 1 frame images are output. There are five modes: 1P SNR, 1P SR, PW SNR, PW SR, RR.

The RGB terminal trigger input and index output interface are as shown below.

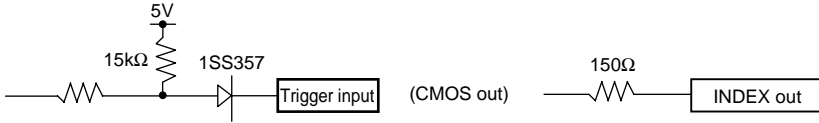

### (1) 1P SNR (1 Pulse Sync Non Reset)

Charge begins to accumulate after the trigger input to the RGB terminal, and 1 field images are output.

#### (1.1) 1 Pulse Trigger SYNC-NON RESET Picture Output Timing

(At Time of One-shot or Continuous External VD/Continuous External HD Input)

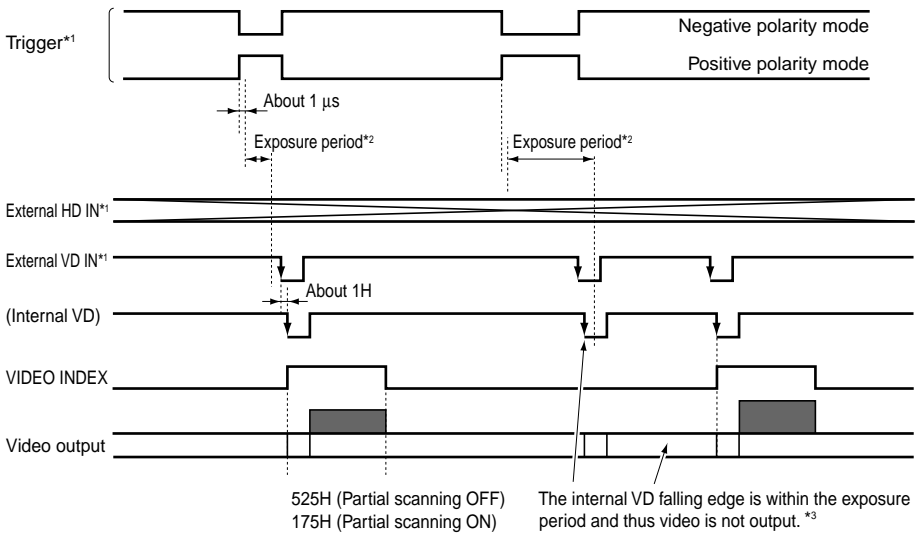

\*1: Externally input signal

\*2: Exposure time is determined by the setting of "(1.3) Changing each setting in E.TRG mode".

\*3: Video is output at the falling edge of the internal VD following completion of the exposure period.

The video and the VIDEO INDEX have a paired relationship.

#### Note:

**When the next trigger is input before completion of the output of the video corresponding to the trigger, there will be an effect on the video.**

**(1. 2) 1 Pulse Trigger SYNC-NON RESET Picture Output Timing (at Time of Internal Sync)**

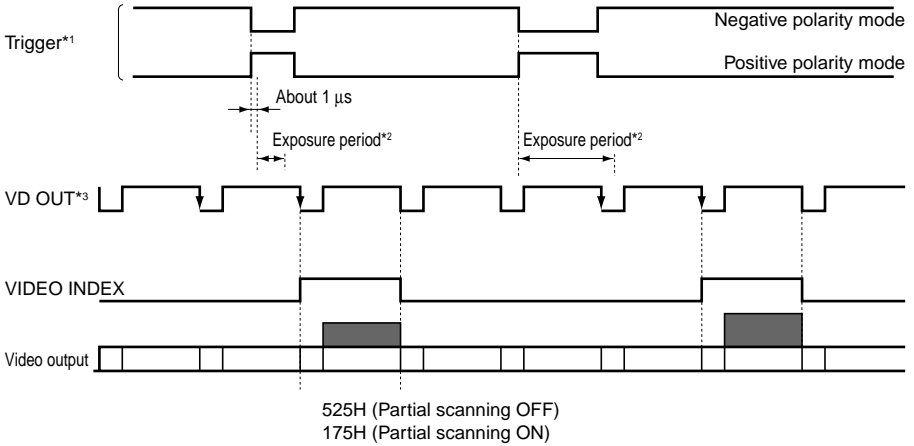

\*1: Externally input signal

\*2: Exposure time is determined by the setting of "(1.3) Changing each setting in E.TRG mode".

As long as there is no external sync input, the internal VD will be output when the rear panel HD/VD signal input/output switch is set to the INT side.

\*3: Video is output at the falling edge of the internal VD following completion of the exposure period.

The video and the VIDEO INDEX have a paired relationship.

**Note:**

**When the next trigger is input before completion of the output of the video corresponding to the trigger, there will be an effect on the video.**

## ( 2 ) 1P SR (1 Pulse Sync Reset)

Charge begins to accumulate after the trigger input to the RGB terminal, the vertical sync signal is reset and field images are output.

### (2. 1) 1 Pulse Trigger SYNC-RESET Picture Output Timing

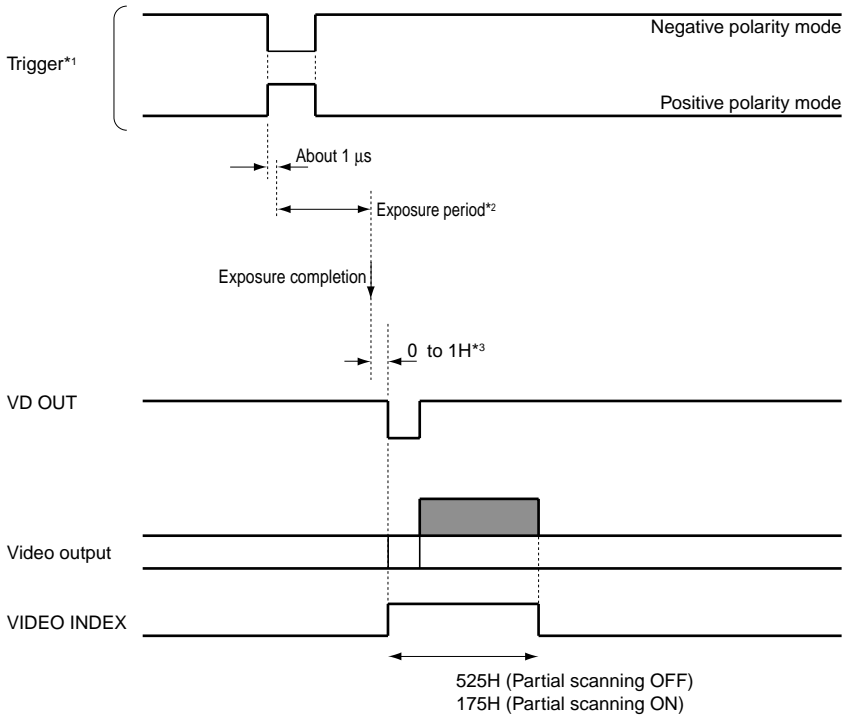

\*1: Externally input signal

\*2: Exposure time is determined by the setting of "(1.3) Changing each setting in E.TRG mode".

\*3: VD is generated after 0 to 1H following the completion of the exposure period and the video is synchronized to this and output.

#### Note:

**When the next trigger is input before completion of the output of the video corresponding to the trigger, there will be an effect on the video.**

**( 3 ) PW SNR (Pulse width trigger SYNC-NON RESET)**

The trigger input to the RGB terminal develops 1 field images.

**(3. 1) Pulse Width Trigger SYNC-NON RESET Picture Output Timing**

**(At Time of One-shot or Continuous External VD/Continuous External HD Input)**

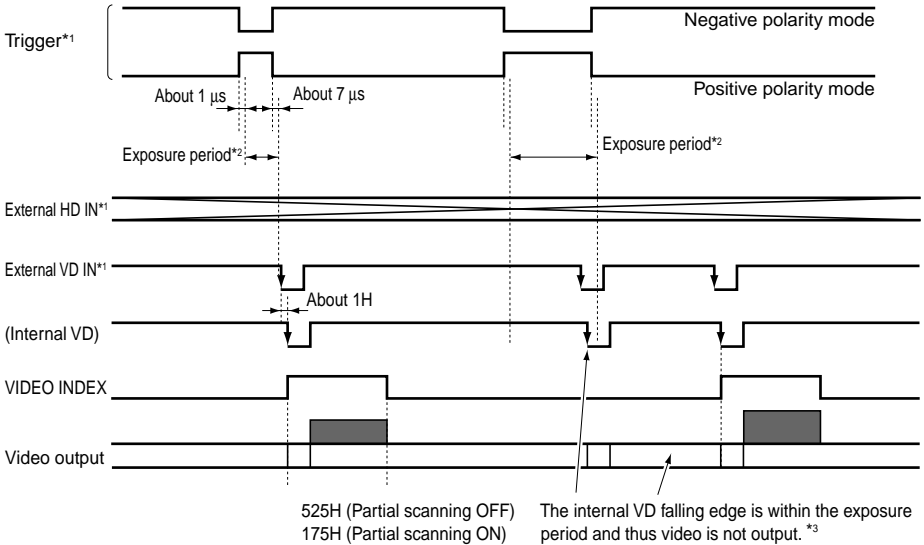

\*1: Externally input signal

\*2: Exposure time = Trigger pulse width + 6 ms

(Valid trigger pulse width is 2 ms or greater for external trigger shutter operation.)

\*3: Video is output at the falling edge of the internal VD following completion of the exposure period.

The video and the VIDEO INDEX have a paired relationship.

**Note:**

**When the next trigger is input before completion of the output of the video corresponding to the trigger, there will be an effect on the video.**

**(3. 2) Pulse Width Trigger SYNC-NON RESET Picture Output Timing (at Time of Internal Sync)**

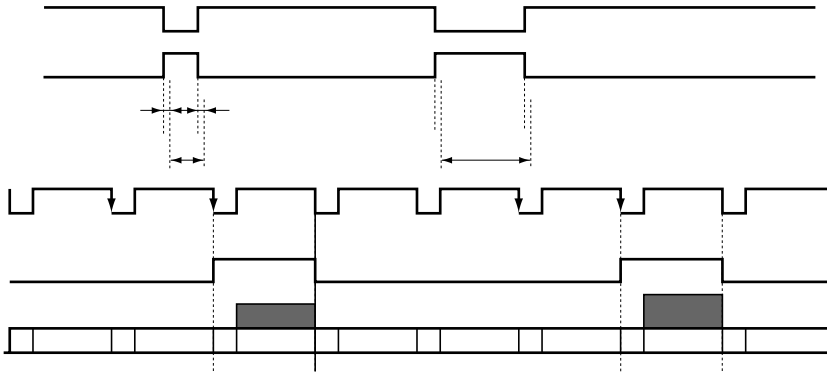

- \*1: Externally input signal
- \*2: Exposure time = Trigger pulse width + 6 ms  
(Valid trigger pulse width is 2 ms or greater for external trigger shutter operation.)
- \*3: As long as there is no external sync input, the internal VD will be output when the rear panel HD/VD signal input/output switch is set to the INT side.
- \*4: Video is output at the falling edge of the internal VD following completion of the exposure period.  
The video and the VIDEO INDEX have a paired relationship.

**Note:**

**When the next trigger is input before completion of the output of the video corresponding to the trigger, there will be an effect on the video.**

**( 4 ) PW SR (Pulse width trigger SYNC-RESET)**

The trigger input to the RGB terminal develops 1 field images.

**(4. 1) 1 Pulse Width Trigger SYNC-RESET Picture Output Timing**

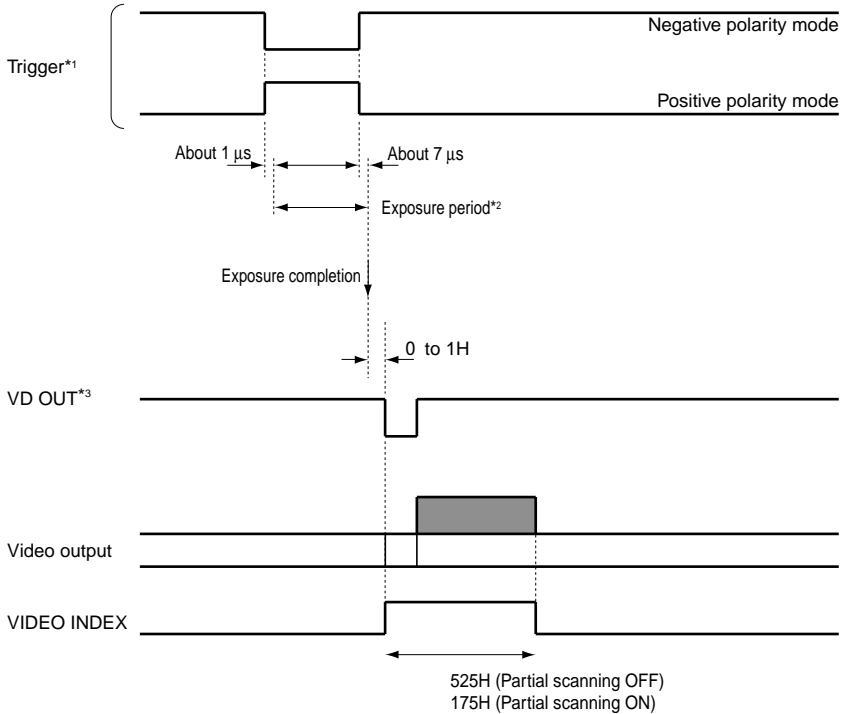

\*1: Externally input signal

\*2: Exposure time = Trigger pulse width + 6 ms

(Valid trigger pulse width is 2 ms or greater for external trigger shutter operation.)

\*3: VD is generated after 0 to 1H following the completion of the exposure period and the video is synchronized to this and output.

**Note:**

**When the next trigger is input before completion of the output of the video corresponding to the trigger, there will be an effect on the video.**

## ( 5 ) RR (Reset restart)

Input of an external reset-restart signal (VD terminal) permits one screen of information to be output at an arbitrary timing.

### (5. 1) Long Term Exposure

When the camera is used and sufficient sensitivity cannot be obtained for the reset-restart function under normal operating conditions, or when observation of the trail of a moving subject is desired, the exposure time can be extended to allow high-sensitivity images to be obtained. To achieve this, please input from an external source a VD signal that has an expanded VD pulse and VD pulse interval.

### (5. 2) Input Timing Chart Example

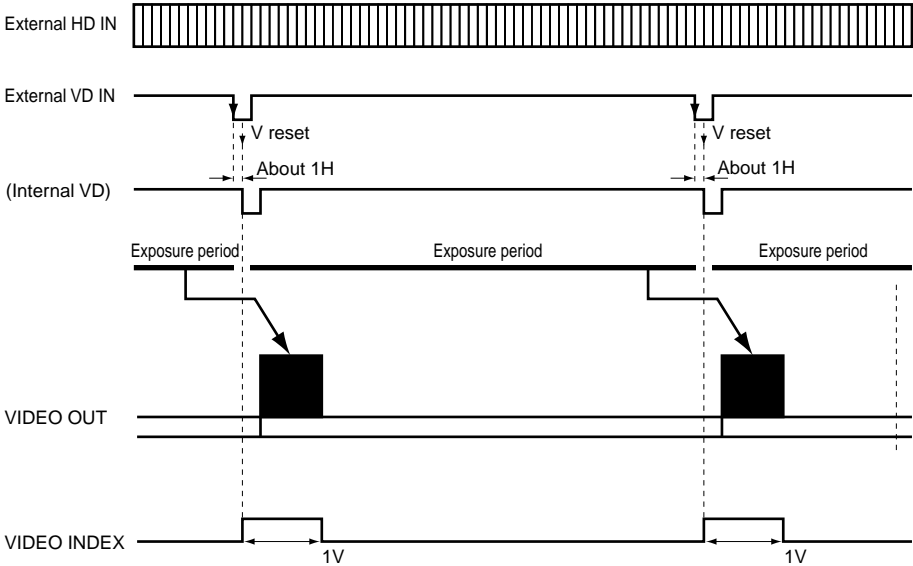

External VD interval: more than 1V

## 7.6 Partial Read

### ( 1 ) Partial Scanning OFF (All pixels scanning)

In this mode, all pixels independent signal from the VIDEO OUT connector is output each 1/60 second (Line order output).

External HD/VD sync is permitted.

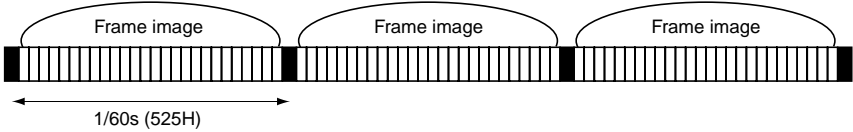

### ( 2 ) Partial Scanning ON

In this mode, the pixel signal of the vertical center portion from the VIDEO OUT connector is output each 1/180 second.

External HD/VD sync is permitted.

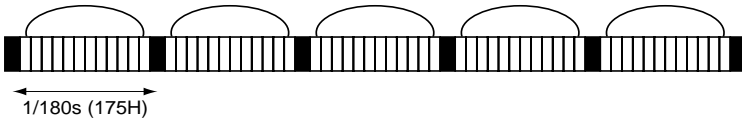

### ( 3 ) When Partial Scanning Mode is ON

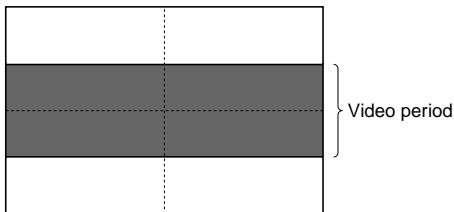
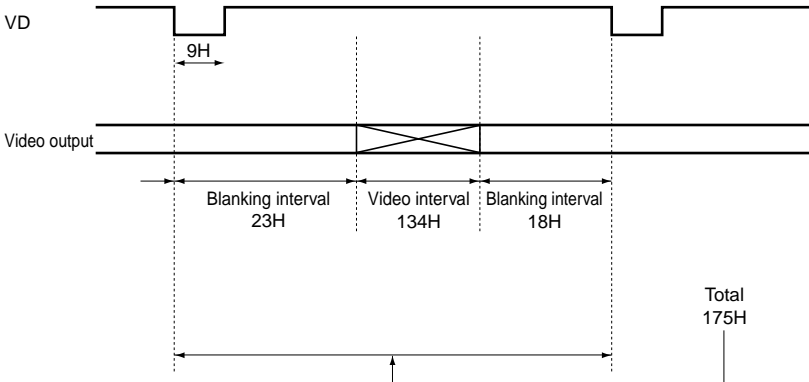

# 8. INPUT OUTPUT SIGNAL SPECIFICATOINS

## ( 1 ) HD/VD Output Amplitude Specifications

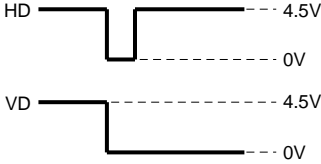

The amplitude level is the representative value when terminated with 10kΩ. Output is enabled when the rear panel HD/VD signal input/output switch is set to the INT side.

## ( 2 ) VIDEO INDEX Output Specifications

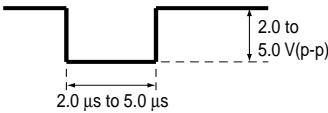

The amplitude level is the representative value when terminated with 10kΩ.

## ( 3 ) VD Input Specifications

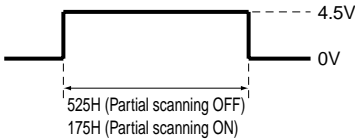

- \* Input impedance: 75Ω or 1kΩ or greater
- \* Input amplitude 2.0 to 5.0 V(p-p) (75Ω termination ON or OFF)
- \* Voltage and pulse width were measured at pin 7 of the 12-pin connector located on the rear panel.

## ( 4 ) HD Input Specifications

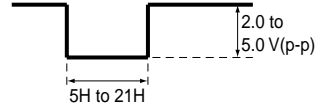

- \* Input impedance: 75Ω or 10kΩ or greater
- \* Input amplitude 2.0 to 5.0 Vp-p (75Ω termination ON or OFF)
- \* Voltage and pulse width were measured at pin 6 of the 12-pin connector located on the rear panel.

## ( 5 ) Trigger Pulse Specifications

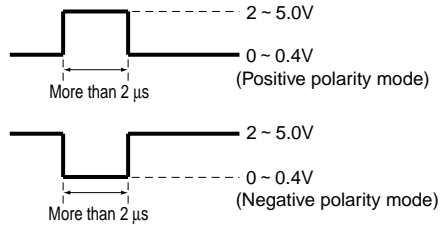

- \* Input impedance: 10kΩ or greater
- \* Voltage and pulse width were measured at pin 11 of the 12-pin connector located on the rear panel.

## ( 6 ) External HD/VD Input Phase Specifications

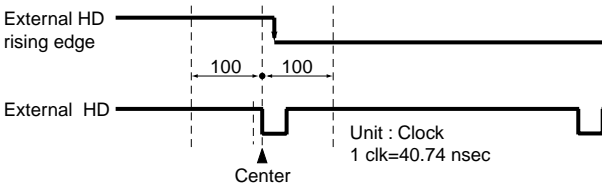

The phase relationship of the external HD and VD should correspond to the center phase (i.e., the external HD falling edge) as illustrated in the above diagram.

### External VD falling edge:

Please input within about 100 clock cycles of the standard center phase.

Note that V sync of the video is output with a delay of about 1H from the external VD at the time of reset-restart and the external trigger mode.

### In the normal mode:

Continuously with the HD period of 31.78 ms and VD period of 16.68 ms (partial scanning ON: 5.56 ms).

Phase timing is as illustrated in the above diagram (with only the falling edge applicable).

### In the reset-restart/external trigger mode:

Continuously with the HD period of 31.78 ms. VD (reset) is at an arbitrary timing with the phase of HD being within the standard of the above diagram.

# 9. CCD OUTPUT WAVEFORM TIMING CHART

## (1) Horizontal Output Waveform Timing Chart

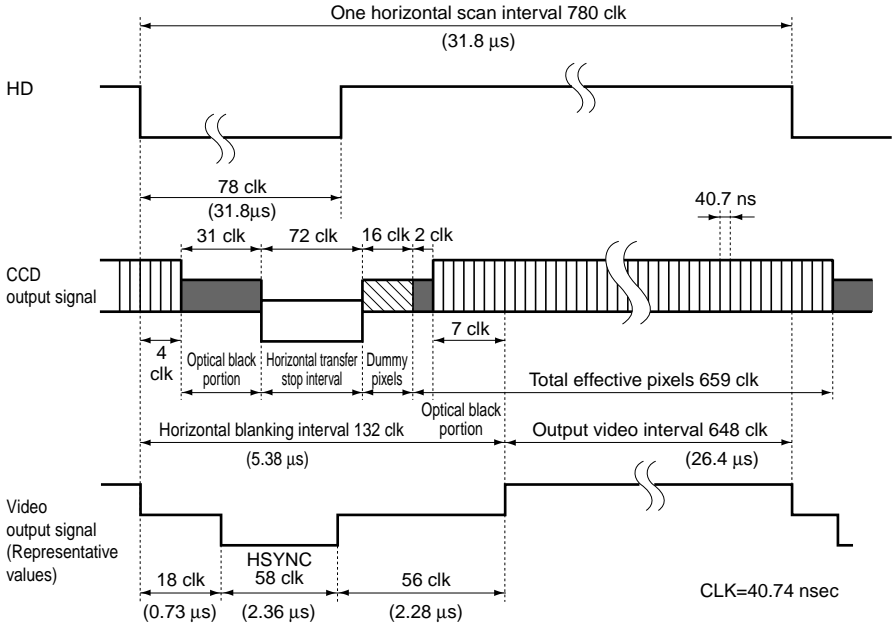

## (2) Vertical Output Waveform Timing Chart

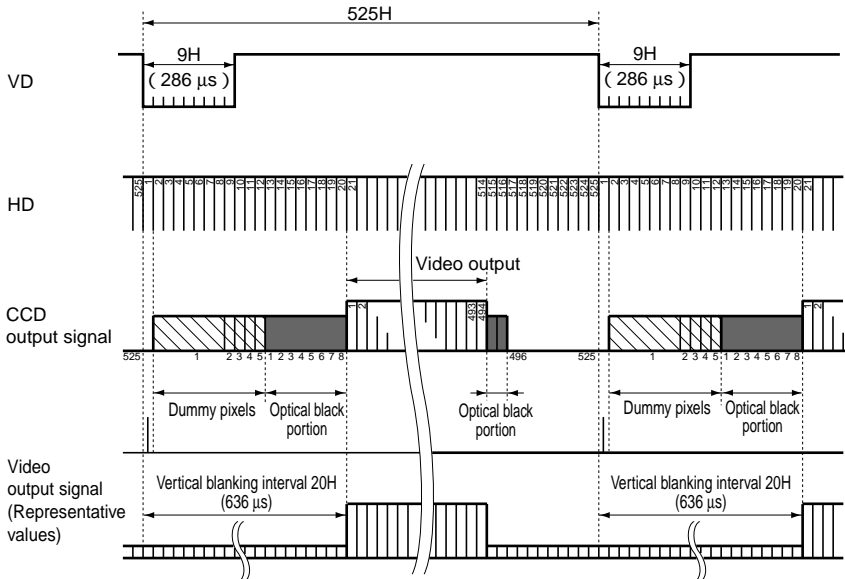

## 10. SPECIFICATIONS

Power supply	DC12V±10%
Power consumption	Approx. 4.3W
Pick-up system	RGB, 3CCD
Image sensor (Effective pixels)	1/3inch All pixels CCD (Horizontal : 659pixels, Vertical : 494pixels)
Scanning system	Progressive scan
Scan frequency	Horizontal : 31.469kHz, Vertical : 59.94Hz
Sync system	Internal/External (Automatic switching)
Horizontal resolution	500TV lines
Sensitivity	F6.8 standard (2000 lx, 3000K)
Minimum illumination	14 lx (F2.2, Sensitivity + 18 dB, 3000K)
SN ratio	62 dB standard (G)
Lens mount	C mount (flange back : 17.526 mm in-air)
Ambient temperature	32 to 104°F (0 to 40°C)
Ambient humidity	Less than 90%
Weight	Approx. 5.74oz (165g)
External dimension	1.73" (W) x 1.73" (H) x 3.07" (D) (44 (W) x 44 (H) x 78 (D) mm) (except for protruded portion)
White balance	AWB (Automatic white balance), MANUAL (Manual)
Gain	MANUAL (Manual), OFF (0 dB)
Output signal	RGB : 75Ω unbalanced, D sub 15 pin connector
External sync input	HD or VD : 2 – 5 V(p-p) Negative
Sync signal output	SYNC : 2.0V±1 V(p-p) 75Ω unbalanced HD, VD, INDEX : 5V <sup>+0.5</sup> / <sub>-1.0</sub> V(p-p), Negative Load impedance : More than 10 kW
External trigger input	TRIGGER : Low level : Less than 0.4V, High level : 3.4 – 5V 1 Pulse : Positive/Negative/Width selectable 2 Pulse : Positive/Negative/Width selectable
Interface	Serial data interface (RS-232C)
Optional parts	EXC-TF05B (RGB cable), etc

# 11. EXTERNAL APPEARANCE DIAGRAM

Unit : mm [inch]

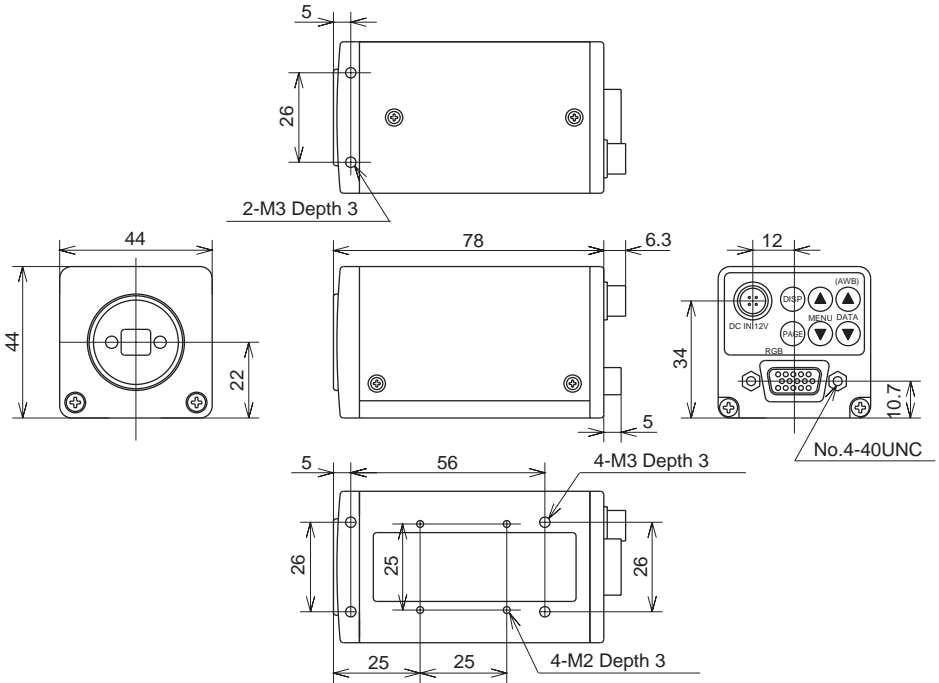

# 12. BEFORE MAKING A SERVICE CALL

Symptom	Items to be checked
No image	<ul style="list-style-type: none"> <li>• Is the power supplied correctly?</li> <li>• Is the lens iris adjusted correctly?</li> <li>• Are the cables connected correctly?</li> <li>• Is the shutter mode set correctly?</li> <li>• Is the image process equipment set correctly?</li> </ul>
Poor color	<ul style="list-style-type: none"> <li>• Is the monitor (TV) adjusted correctly?</li> <li>• Is the white balance of the camera adjusted correctly?</li> <li>• Is the illumination dark?</li> </ul>

## LIMITED WARRANTY TOSHIBA CCD CAMERA

**Promptly register your product with Toshiba on-line at [www.toshiba.com/taisisd](http://www.toshiba.com/taisisd).** By registering your product you will be eligible for periodic updates, announcements, and special offers. You will have access to extended warranty options, upgrades (as applicable), useful tips, on-line troubleshooting, and the ability to schedule service on-line if necessary. The Imaging Systems Division of Toshiba America Information Systems, Inc. ("ISD") makes the following limited warranties. These limited warranties extend to the Original End-User ("Your[r]").

### Limited One (1) Year Warranty of Labor and Parts

ISD warrants this product and parts against defects in material or workmanship for a period of one year from the date of original retail purchase by the end-user. During this period, ISD will repair or replace a defective product or part with a new or refurbished item. The user must deliver the entire product to an ISD authorized service center. The user is responsible for all transportation and insurance charges for the product to the Service Center. ISD reserves the right to substitute Factory Refurbished Parts and / or Factory Refurbished Product in place of those in need of repair.

### Step-by-step Procedures - How to Obtain Warranty Service

- [1] Verify operation of the unit by checking the instruction manual
- [2] If there is a defect in material or workmanship, contact an Authorized Service Provider within 30 days after the product fails to comply with specifications.
- [3] Arrange for delivery of the product to the ISD authorized service center. Products must be insured and securely packed, preferably in the original shipping carton. A letter explaining the defect and a copy of the bill of sale or other proof of purchase must be enclosed with a complete return street address and daytime telephone number. Charges for transportation and insurance must be prepaid by the end-user.

**Questions?** If you have any questions, please check the Toshiba Imaging Systems Division Web site as follows:

**Website:** <http://www.toshiba.com/taisisd/indmed>

### Your Responsibility, warranties are subject to the following conditions:

- [1] You must retain the bill of sale or provide other proof of purchase.
- [2] You must schedule service within thirty days after you discover a defective product or part.
- [3] All warranty servicing of this product must be made by a Toshiba ISD Authorized Service Provider.
- [4] The warranty extends to defects in material or workmanship as limited above, and not to any products or parts that have been lost or discarded by user. The warranty does not cover damage caused by misuse, accident, improper installation, improper maintenance, or use in violation of instructions furnished by ISD. The warranty does not extend to units which have been altered or modified without authorization of ISD, or to damage to products or parts thereof which have had the serial number removed, altered defaced or rendered illegible.

**ALL WARRANTIES IMPLIED BY STATE LAW, INCLUDING THE IMPLIED WARRANTIES OF MERCHANTABILITY AND FITNESS FOR A PARTICULAR PURPOSE, ARE EXPRESSLY LIMITED TO THE DURATION OF THE LIMITED WARRANTIES SET FORTH ABOVE. Some states do not allow limitations on how long an implied warranty lasts, so the above limitation may not apply. WITH THE EXCEPTION OF ANY WARRANTIES IMPLIED BY STATE LAW AS HEREBY LIMITED, THE FOREGOING EXPRESS WARRANTY IS EXCLUSIVE AND IN LIEU OF ALL OTHER WITH RESPECT TO THE REPAIR OR REPLACEMENT OF ANY PRODUCTS OR PARTS. IN NO EVENT SHALL ISD BE LIABLE FOR CONSEQUENTIAL OR INCIDENTAL DAMAGES. Some states do not allow the exclusion or limitation of incidental or consequential damages so the above limitation may not apply.**

No person, agent, distributor, dealer, service station or company is authorized to change, modify or extend the terms of these warranties in any manner whatsoever. The time within which an action must be commenced to enforce any obligation of ISD arising under this warranty or under any statute, or law of the United States or any state thereof, is hereby limited to one year from the date you discover or should have discovered, the defect. This limitation does not apply to implied warranties arising under state law. Some states do not permit limitation of the time within which you may bring an action beyond the limits provided by state law so the above provision may not apply to user. This warranty gives the user specific legal rights, and user may also have other rights, which may vary from state to state.

**TOSHIBA AMERICA INFORMATION SYSTEMS, INC.**

**Imaging Systems Division**

Copyright © 2002 Toshiba America, Inc. All rights reserved.

**TOSHIBA**