



**For FA/Machine Vision
3CCD Camera**

Applicable camera (model)

1	2/3	1/2	1/3	1/4

TF8DA-8B

NEW

FIXED
Fixed Focal

3CCD
For 3CCD
Camera

MANUAL
Manual Iris

C-mt
C Mount

METAL
Metal Mount



- Special design for optimizing the image quality of 3CCD cameras.
- Low-distortion design achieving accurate image input.
- Compact, lightweight and robust design, supporting various systems.
- Faithful color reproduction for 3CCD cameras, best suited for advanced monitoring applications.
- Robust enclosure that can withstand vibrations and shocks. Equipped with locking screws for the iris and the focus.

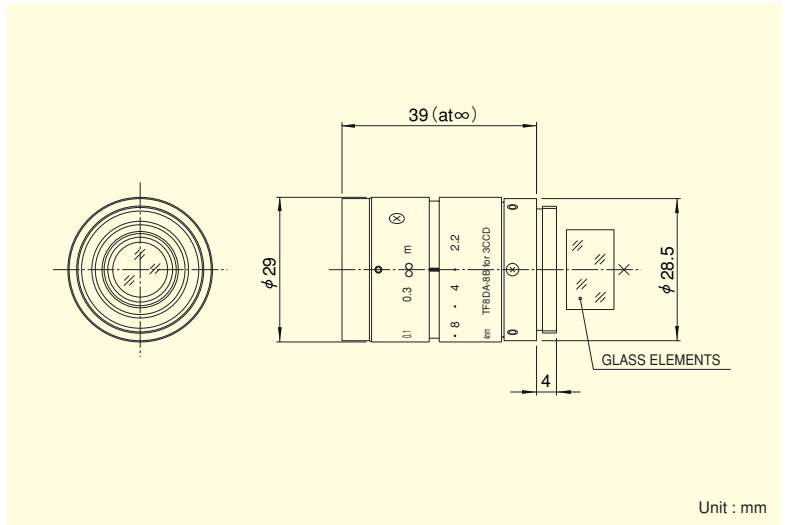

Unit : mm

Focal Length (mm)		8
Iris Range		F2.2 ~ F16 · Close
Operation	Focus	Manual
	Iris	Manual
Angle Of View (H×V)	1/3"	33°24' × 25°22'
Focusing Range (From Front Of The Lens) (m)		$\infty \sim 0.1$
Object Dimensions at M.O.D. (H×V) (mm)	1/3"	66 × 50
Back Focal Distance (in air) (mm)		14.83
Exit Pupil Position (From Image Plane) (mm)		-176
Filter Thread (mm)		M25.5 × 0.5
Mount		C
Mass (g)		60
Remarks	•With Metal Mount •With Locking Screw for Iris and Focus	

3CCD CAMERA LENSES